

# In-Line

The Velvet Drive® “71” and “72” designations indicate input horsepower ranges. There are two basic configurations of transmissions in the 71 and 72 ratings. The most popular model is the in-line unit. “In-line” indicates that the input and output shafts of the transmission are on the same axis.

Direct drive versions of the in-line models are frequently used on high horsepower, light weight boats. The reduction ratio versions use an additional planetary gear set to allow the use of larger propellers for greater pulling power at lower shaft speeds.

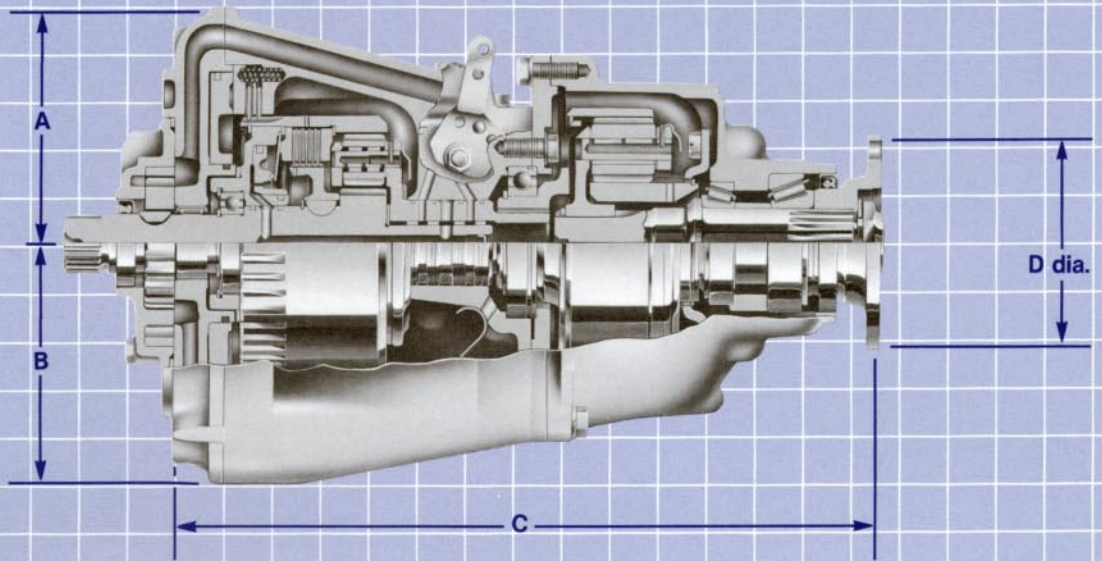

## Dimensions Inches (millimeters)

Reduction Models	A	B	C	D dia.
71C (10-17)	5.63 (143.00)	5.69 (144.53)	16.89 (429.01)	5.00 (127.00)
72C (10-18)	5.63 (143.00)	5.69 (144.53)	17.79 (451.86)	5.00 (127.00)
Direct Drive Models	A	B	C	D dia.
71C (10-17)	5.63 (143.00)	5.69 (144.53)	10.50 (266.70)	4.00 (101.60)
72C (10-18)	5.63 (143.00)	5.69 (144.53)	11.44 (290.58)	5.00 (127.00)

### Model 71C (10-17) General Information

Available Ratios . . . . . 1.00, 1.52, 1.88\*, 2.10, 2.57, 2.91 : 1.00  
 Shaft Rotation . . . . . output same as engine unless noted  
 by asterisk (\*)  
 Approximate Dry Weight (direct drive) . . . . . 95 lbs. (43.1 kg)  
 Approximate Dry Weight (reduction) . . . . . 145 lbs. (65.8 kg)

### Model 72C (10-18) General Information

Available Ratios . . . . . 1.00, 1.52, 1.88\*, 2.10, 2.57, 2.91 : 1.00  
 Shaft Rotation . . . . . output same as engine unless noted  
 by asterisk (\*)  
 Approximate Dry Weight (direct drive) . . . . . 109 lbs. (49.4 kg)  
 Approximate Dry Weight (reduction) . . . . . 153 lbs. (69.4 kg)

# Classifications/Ratings

## Service Classifications:

**Pleasure craft:** Full throttle used approximately 5% of total running time. Typical cruising is at 80% or less of maximum rated engine speed. Engine running time is 400 or less hours per year. Applications in boats designed as pleasure craft and used for commercial use, such as charter boats or party fishing boats, are considered light duty commercial applications.

**Light duty commercial:** Full throttle used approximately 5% of total running time. Longer running periods with throttle setting at 75% or less of maximum rated engine

speed. Engine running time is up to 1500 hours per year. Light duty commercial applications include sport fisherman boats, party fishing boats, crew boats, search & rescue boats, and patrol boats.

**Heavy duty commercial:** Full throttle used up to approximately 5% of total running time. Longer running periods up to 80% of maximum rated engine speed. Engine running time is up to 2500 hours per year. Heavy duty applications include towboats, heavy supply boats, ferries, and offshore fishing trawlers.

## Important Notes:

**System torsionals:** System related noises or vibrations can occur at low engine speeds. They can cause gear rattle and result in damage to the boat engine as well as the transmission. Velvet Drive Transmissions, a Division of Regal-Beloit Corporation is not responsible for total system-related torsionals of this type.

**Specifications:** All specifications and descriptive data shown are nominal and subject to change without notice.

**Lubrication:** Dexron IIE, Dexron III, or any transmission fluid which meets Detroit Diesel Allison C-4 specification are recommended for use in all Velvet Drive® transmissions.

**Applications:** Matching of engine, transmission model, transmission ratio and propeller size is important. The combination must allow the engine to obtain maximum rated engine RPM. Specific applications should be referred to Velvet Drive® transmission distributors for assistance.

### SERIES 71C

(Assembly numbers 10-04 and 10-17)

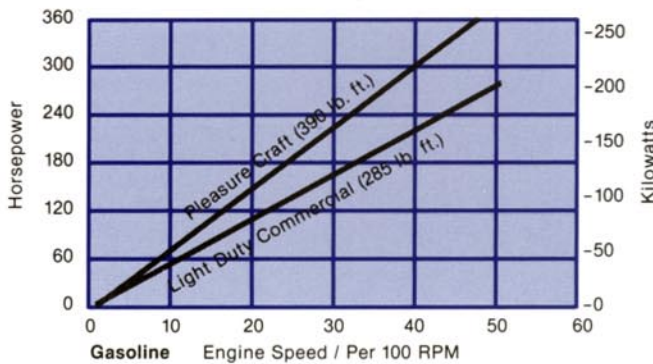

### SERIES 71C

(Assembly numbers 10-04 and 10-17)

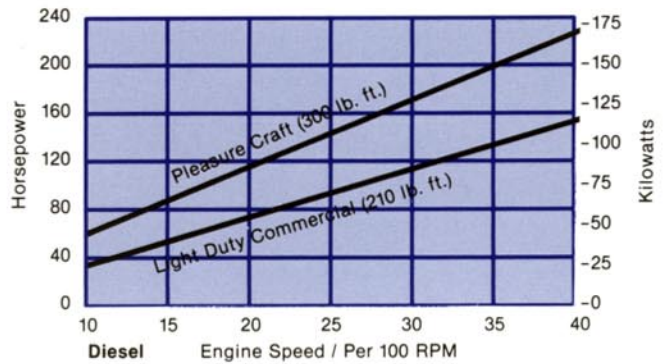

## Model 72C Ratings:

This model is broken into three groups of assemblies. Below are listed the Model 72C assemblies available and the proper set of rating charts applicable to each assembly. Charts are located on back cover of brochure.

Assembly No.	Description	Chart Applicable
10-05-000-002	V-Drive 1.99:1 ratio	A
10-05-000-003	V-Drive 1.99:1 ratio	C
10-05-000-004	V-Drive 2.49:1 ratio	C
10-05-000-005	V-Drive 2.49:1 ratio	B
10-05-000-010	V-Drive 1.51:1 ratio	B
10-05-000-011	V-Drive 1.51:1 ratio	B
10-05-000-012	V-Drive 1.21:1 ratio	B
10-05-000-013	V-Drive 1.21:1 ratio	B

Assembly No.	Description	Chart Applicable
10-18-000-002	In-Line 1:1 ratio	A
10-18-000-004	In-Line 1.52:1 ratio	B
10-18-000-106	In-Line 1.88:1 ratio	B
10-18-000-007	In-Line 2.10:1 ratio	B
10-18-000-008	In-Line 2.10:1 ratio	B
10-18-000-010	In-Line 2.57:1 ratio	A
10-18-000-012	In-Line 2.91:1 ratio	A
10-18-000-014	In-Line 1:1 ratio	A

# Ratings

## SERIES 72C (Group A)

(Assembly numbers 10-05 and 10-18)

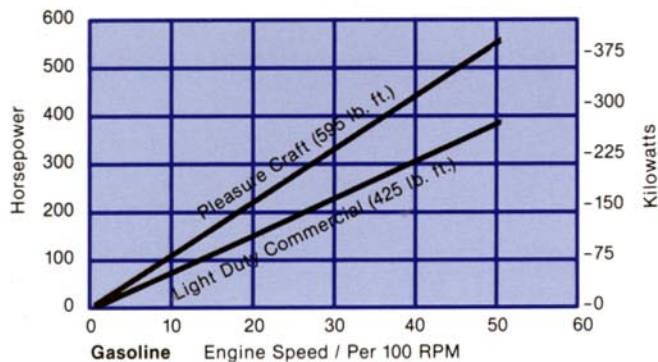

## SERIES 72C (Group A)

(Assembly number 10-05 and 10-18)

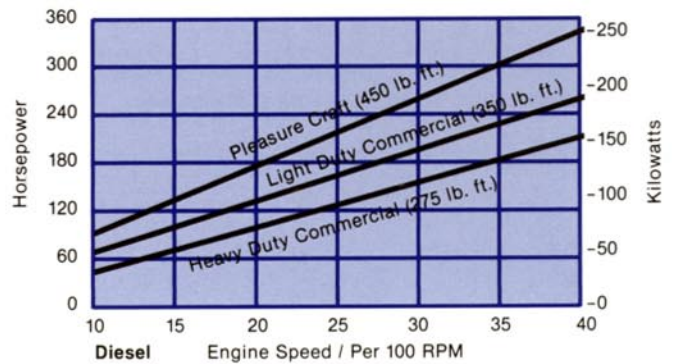

## SERIES 72C (Group B)

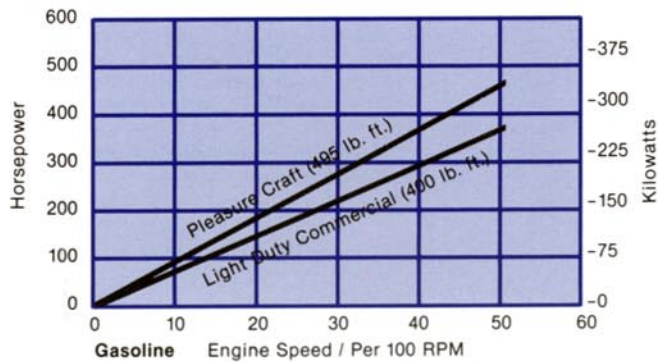

## SERIES 72C (Group B)

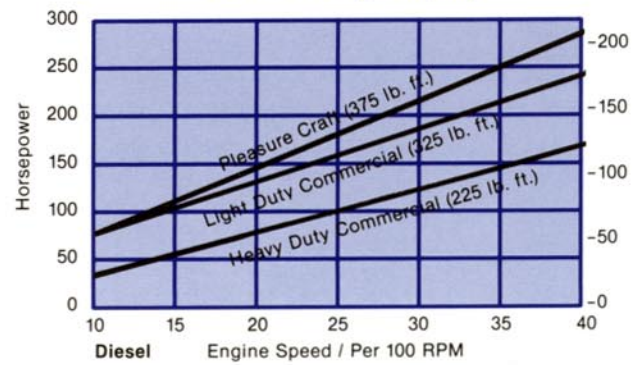

## SERIES 72C (Group C)

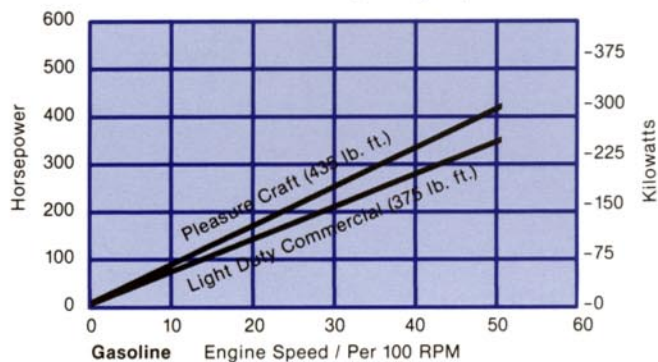

## SERIES 72C (Group C)

